

Alien

Fernando Gilgado

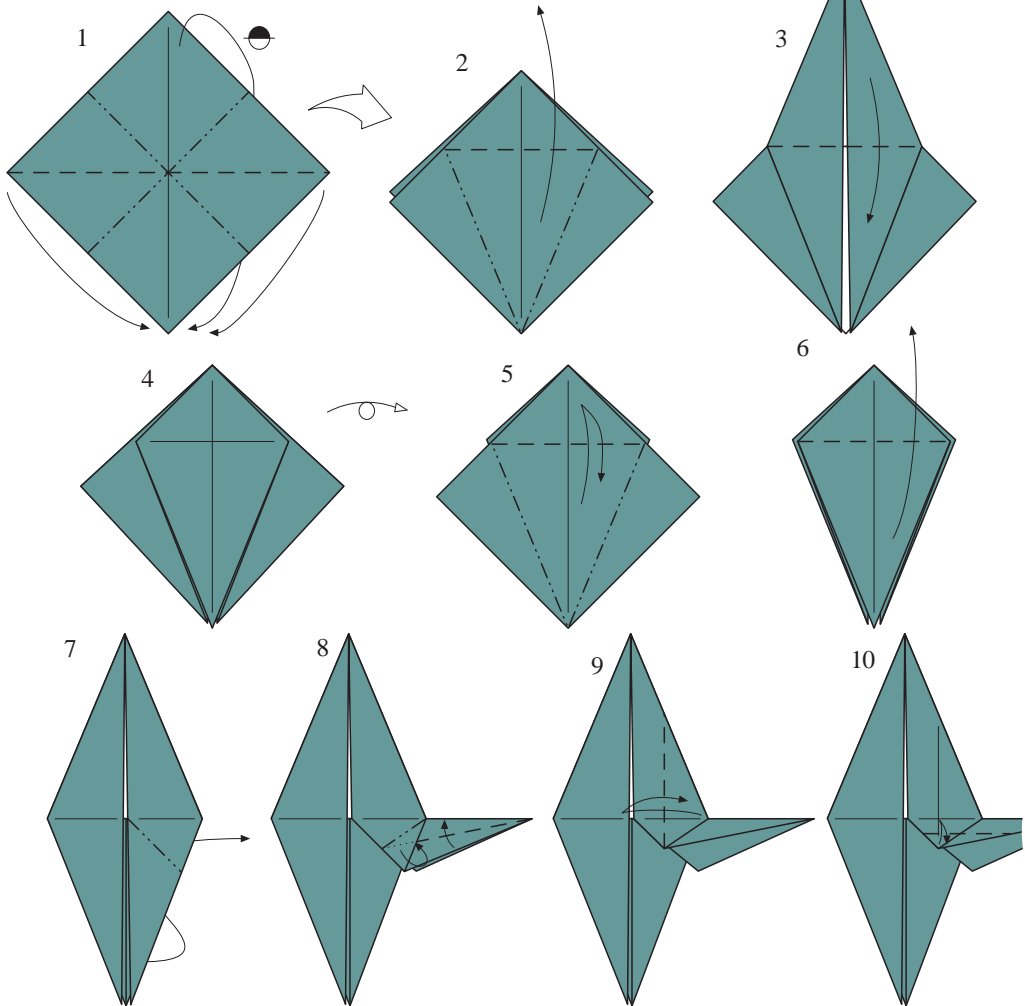
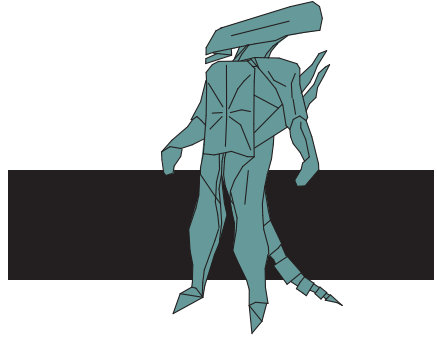

ASOCIACIÓN ESPAÑOLA DE PAPIROFLEXIA

APTDO. DE CORREOS 13.156 - 28080 MADRID

CORREO ELECTRÓNICO: aepinet@publinet.com

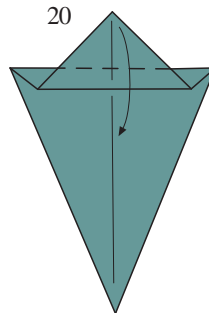
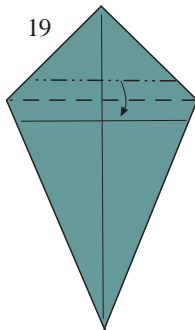
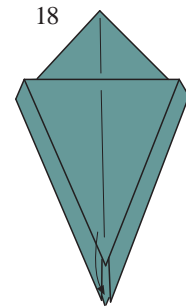
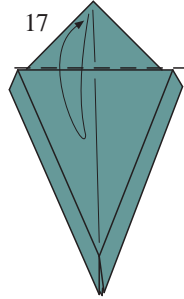
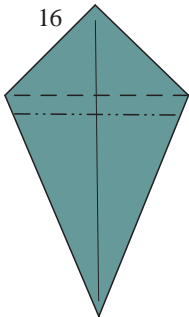
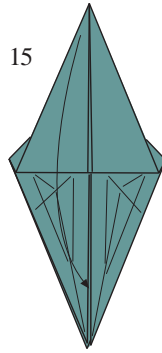
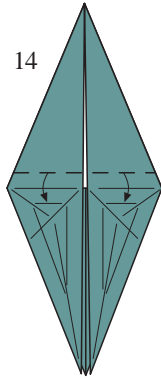
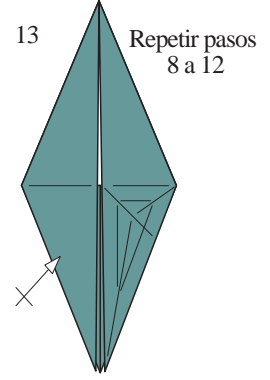
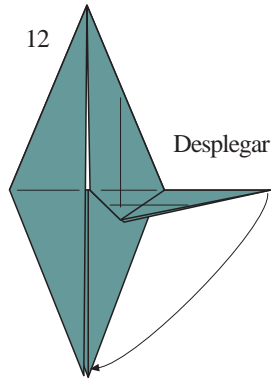
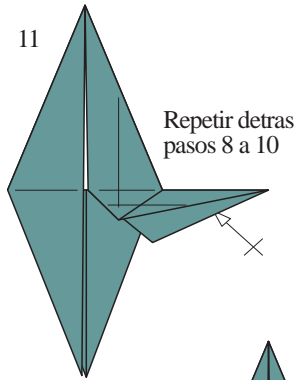

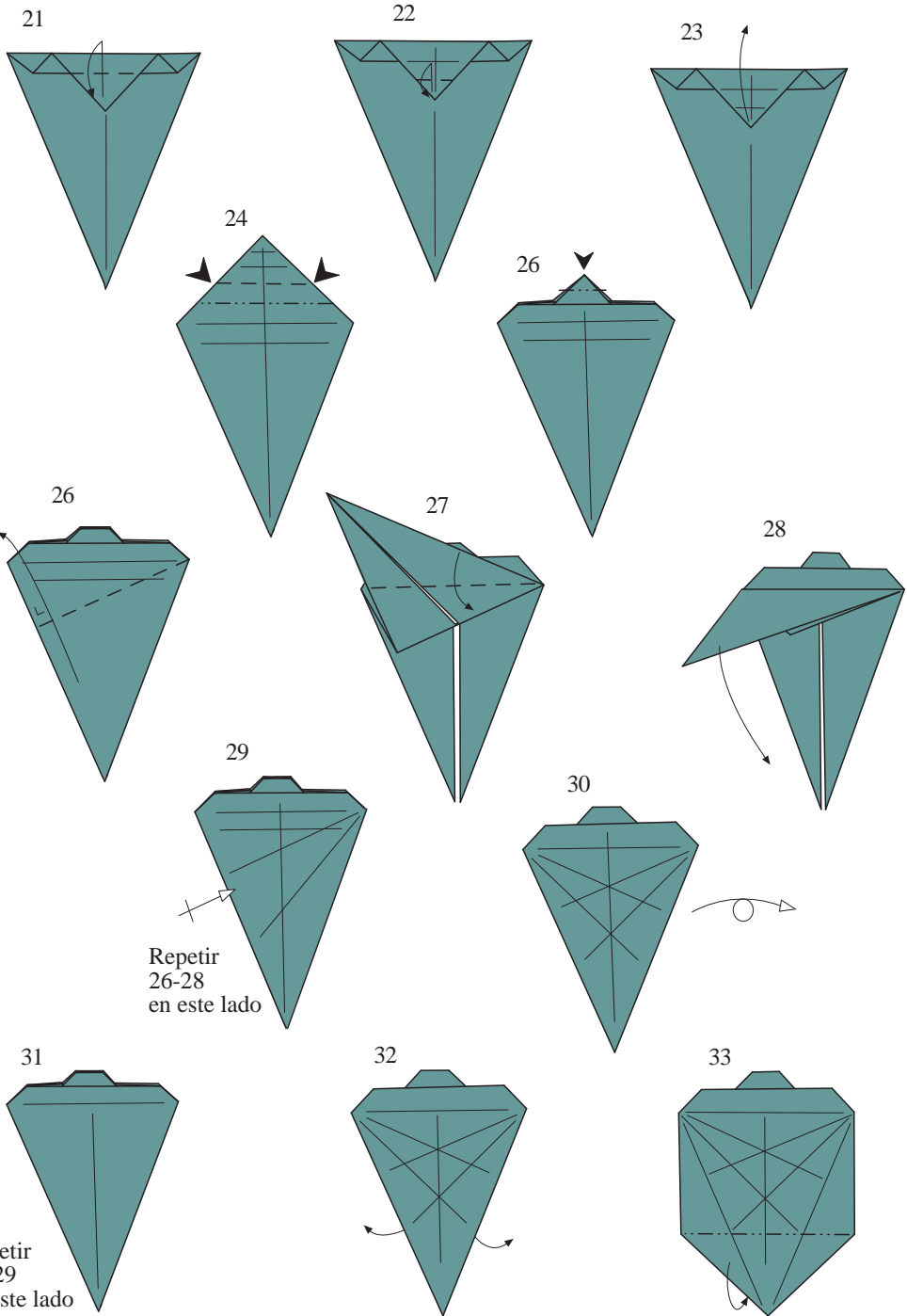

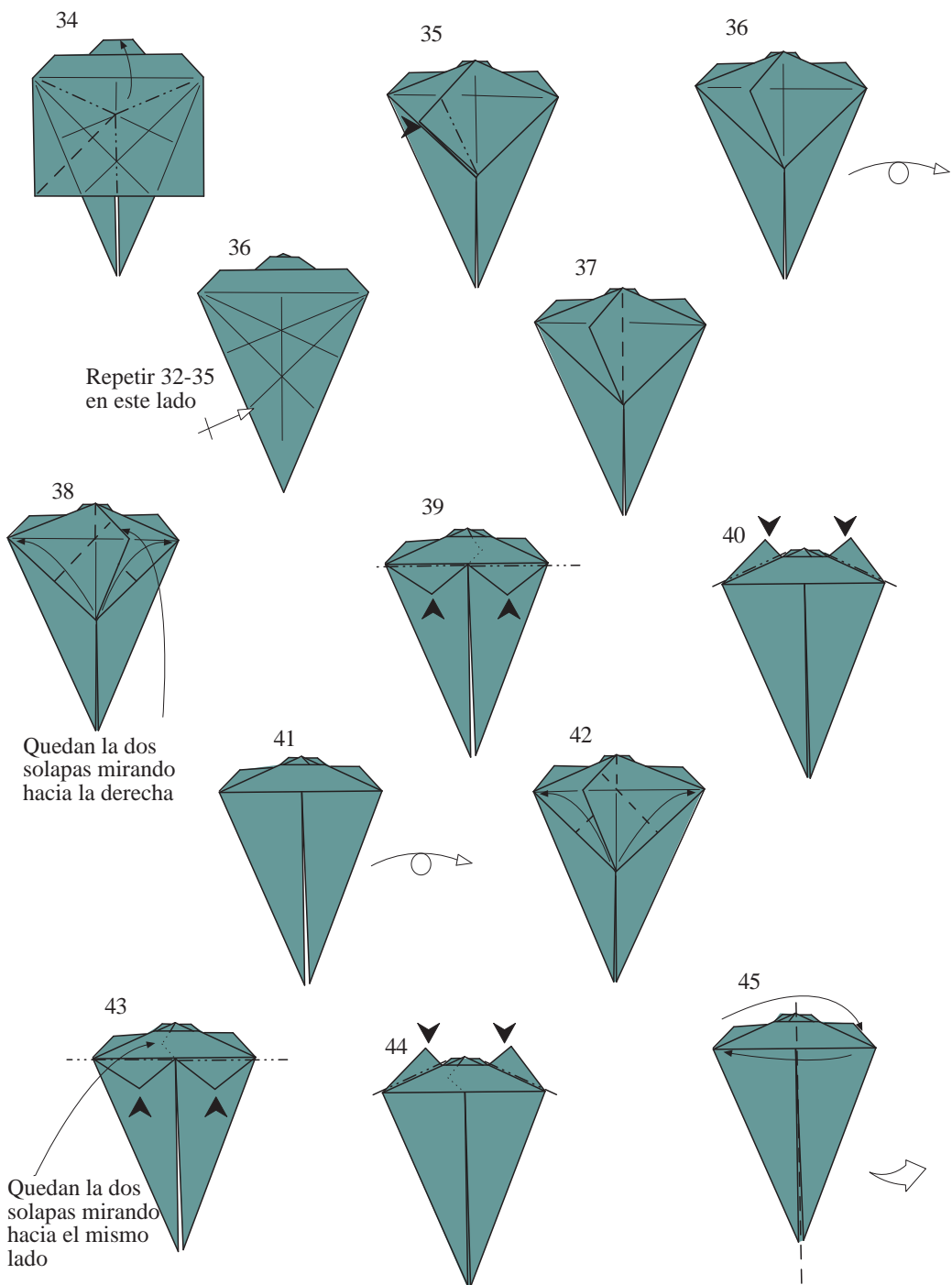

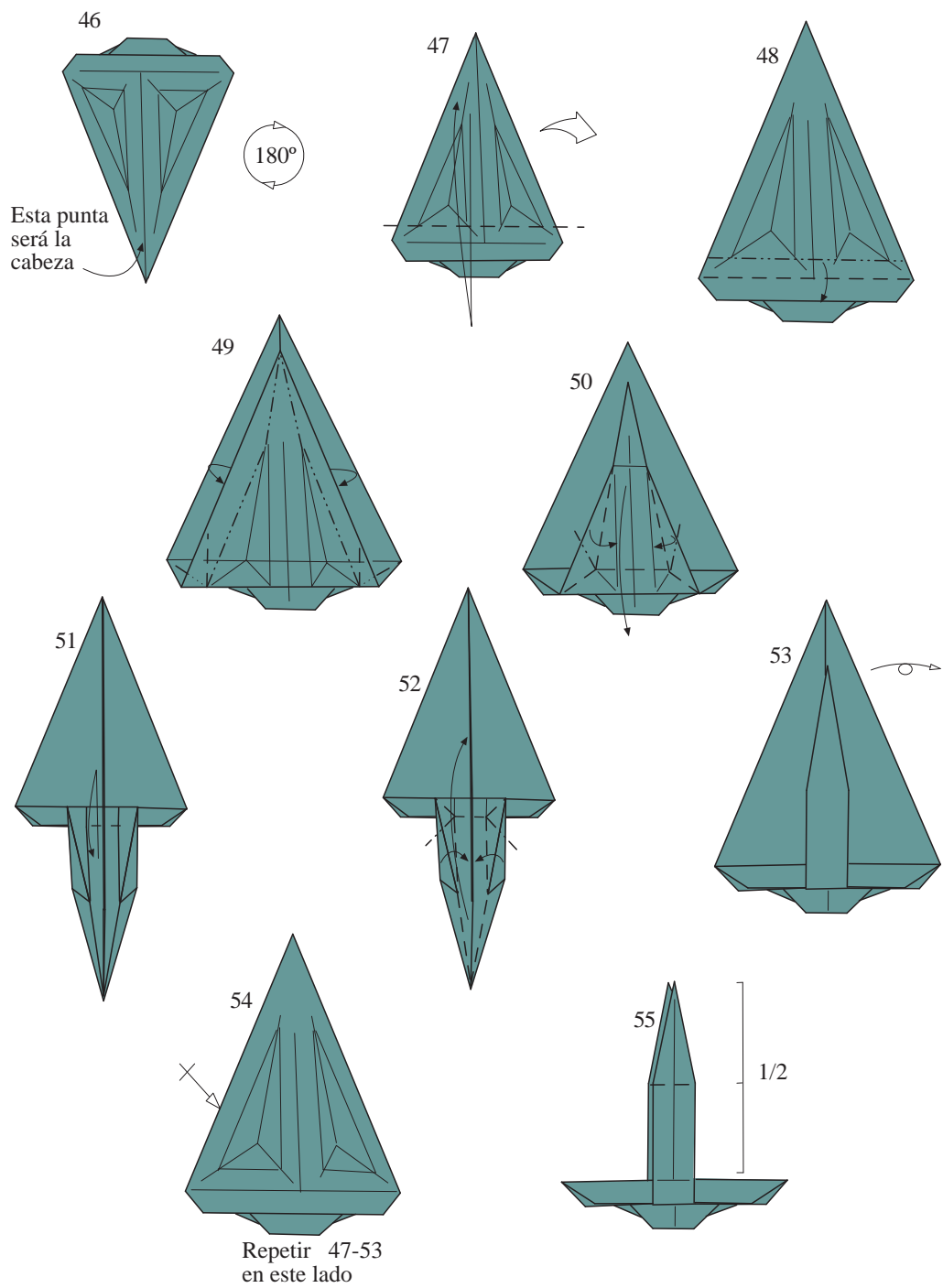

ASOCIACIÓN ESPAÑOLA DE PAPIROFLEXIA

APTDO. DE CORREOS 13.156 - 28080 MADRID

CORREO ELECTRÓNICO: aepinet@publinet.com

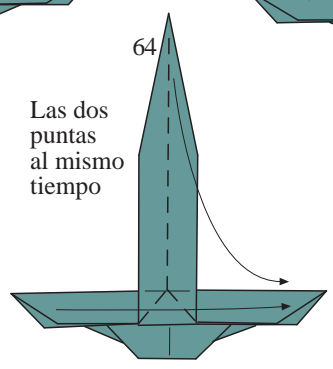
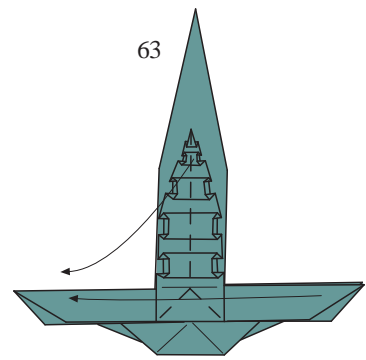
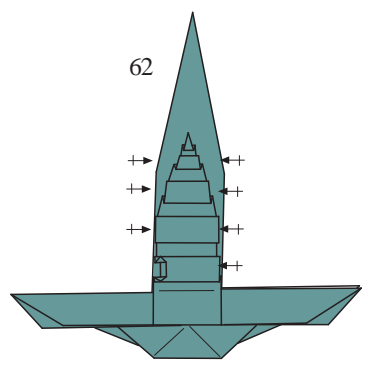
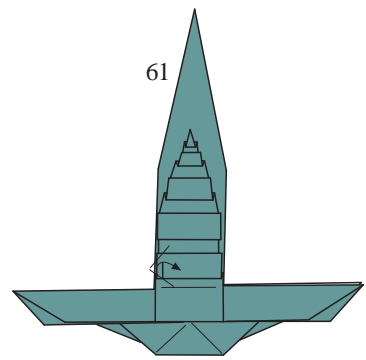
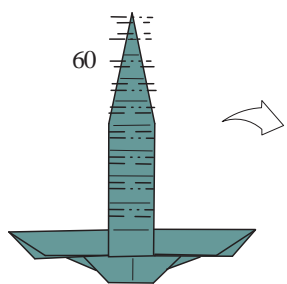
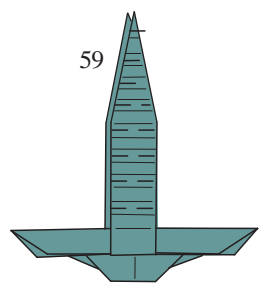
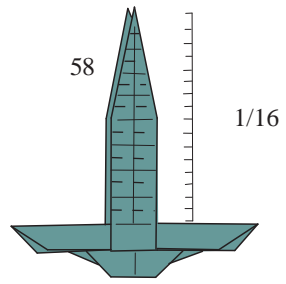
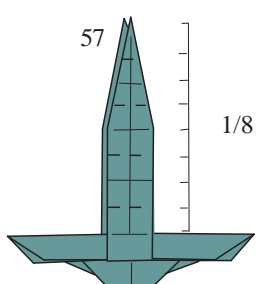
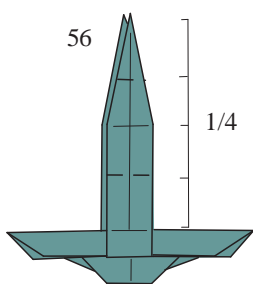

Las dos
puntas
al mismo
tiempo



65

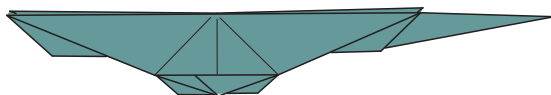

66

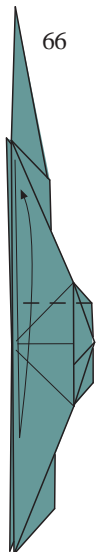

67

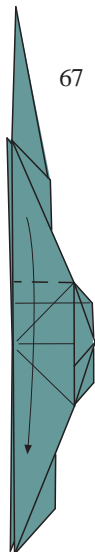

68

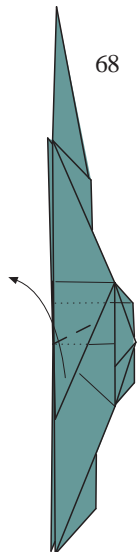

69

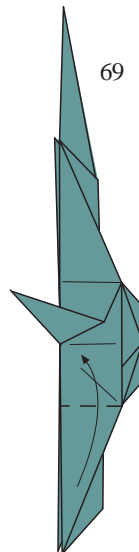

70

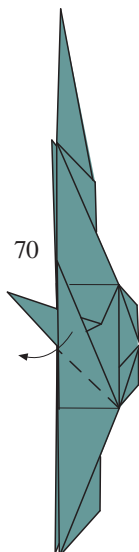

71

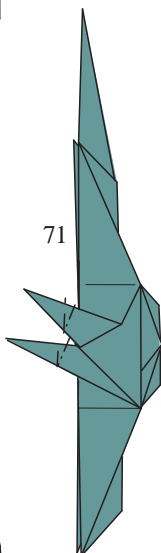

72



Repetir
66-71

73

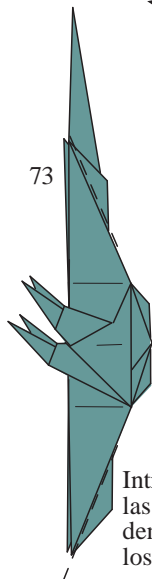

74

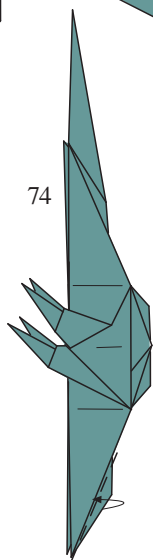

75

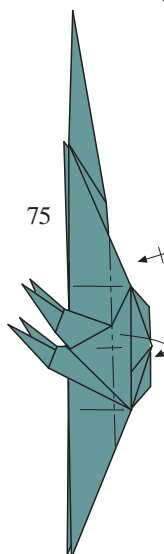

76

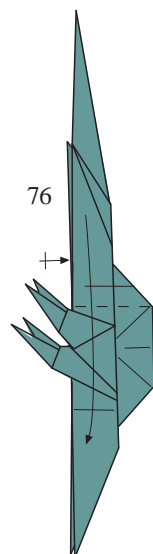

Introducir
las solapas
dentro de
los bolsillos



ASOCIACIÓN ESPAÑOLA DE PAPIROFLEXIA

APTDO. DE CORREOS 13.156 - 28080 MADRID

CORREO ELECTRÓNICO: aepinet@publinet.com

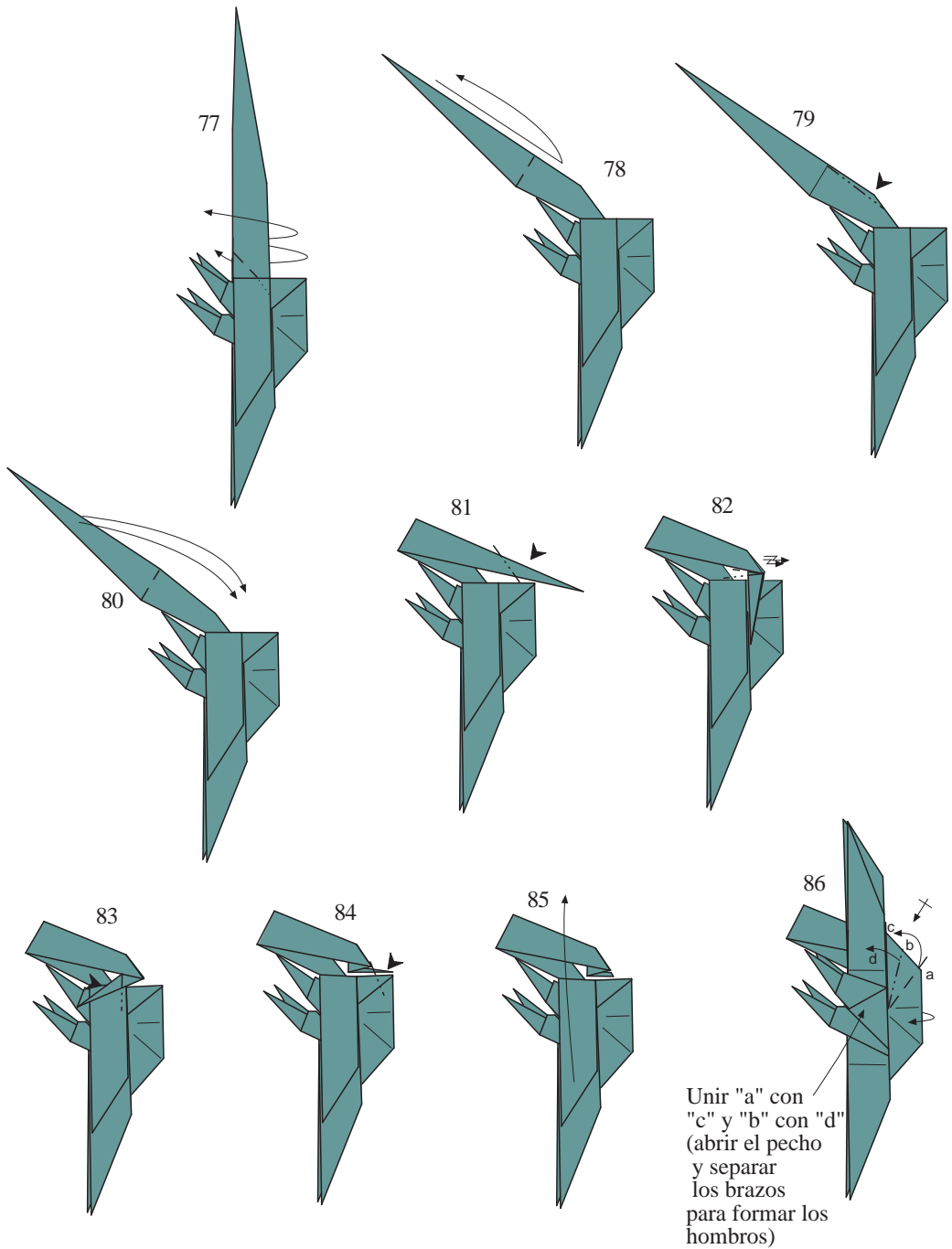

Unir "a" con "c" y "b" con "d" (abrir el pecho y separar los brazos para formar los hombros)



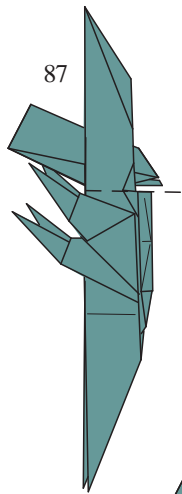

87

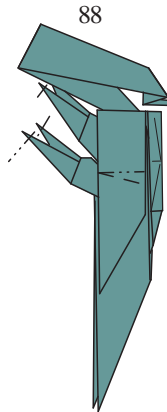

88

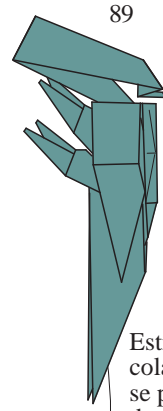

89

Estirar la cola lo que se pueda (se despliega parte del modelo)

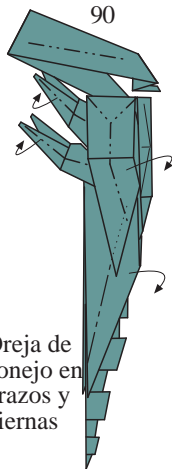

90

Oreja de conejo en brazos y piernas

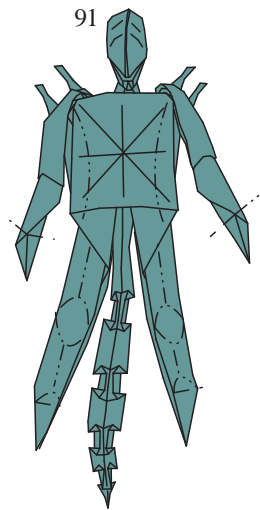

91

